

Supakwik **Supatap**

User Guide / Installation Instructions



User Guide & Installation Instructions

Table of Contents

Introduction	3
Warnings	3
Intended Use & Appliance Positioning	3
Safety	4
General	4
Normal Operation	5
Supatap	5
Changing Default Operation Modes – Tap Safety & Power Saving Levels	6
User Power Saving Features	7
Hot and Cold Water Mixer	7
Care & Maintenance	8
Filters Replacement	8
Warranty, Terms & Conditions	9
Product Support	9
Installation Instructions	11
Positioning, Electrical Services & Filter Fitment	11
Water Supply & Tap Installation	12
Installing BF Series - 2 in 1 Models	13
Installing BC Series – 2 in 1 Models	14
Installing BCF Series – 3 in 1 Models	15
Installing BCFHC Series – 5 in 1 Models	16
Hot and Cold Mixer Tap (optional)	17
Commissioning and Testing	17
Maintenance Mode – resetting default filter initiation periods	18
General Specifications	19
Fault Codes	20

Introduction

Thank you and congratulations on purchasing your Australian designed and manufactured Supakwik Supatap appliance.

Your Supatap has been developed with experience gained from many years in the boiling water industry. Supakwik brought you "Power Management" in its overbench range and once again Supakwik is the world leader in the field by introducing motion controlled energy saving features in its Supatap range, giving you the most advanced power saving features unsurpassed in the industry, patented.

Your appliance has been manufactured in Australia from the highest quality food grade materials utilizing automated machining and assembly processes. The copper tank is manufactured from high grade copper and the tap from brass, chrome plated.

This booklet contains useful information on the operation and care of your appliance as well as important warnings and safety tips. Please take a few moments to read this booklet so you can enjoy many years of trouble free service.

From page 11 the contents are directed at the installer. The user may choose to read these sections to gain a technical understanding of the product and its installation requirements.

This appliance is intended to be used in household and similar applications such as:

- Staff kitchen areas in shops, offices and other working environments.
- Farm houses.
- By clients in hotels, motels and other residential type environments.
- Bed and breakfast type environments.



Warnings

For continued safety of this appliance it must be installed by a suitably qualified person and maintained in accordance with the manufacturer's instructions. This appliance is intended for indoor use only and to be mounted in a dry cupboard space.

The Supatap must be permanently connected to a mains potable water supply, and not by a hose-set. Refer to the Australian drinking water guidelines.

The filter must be replaced when the status LED flashes. Typically this will occur after approximately 10,000 litres has been drawn from the product or a specified time period.

Cleaning and user maintenance shall not be carried out by children. The appliance should be handled with caution at all times to avoid any damage that may cause improper operation.

The vent located at the spout of the tap must not be blocked or obstructed. If the supply cord is damaged it must be replaced by Supakwik Water Heaters Pty. Ltd, a service agent or a suitably qualified tradesperson.

Safety

Boiling water can cause severe burns and as such, this appliance must be handled with caution at all times. This appliance must be operated as per these instructions.

Children should be supervised to ensure that they should not play with the appliance. This appliance can be used by children aged from 8 years and above and persons with reduced physical, sensory or mental capabilities or lack of experience and knowledge if they have been given supervision or instruction concerning use of the appliance in a safe way and understand the hazards involved

When operating the tap ensure your hands and arms are clear of the outlet delivering the boiling water.

All models include dual safety lock options. When in either of these lock modes, the boiling water lever is rendered inactive (see Safety Lock page 6). As a further safety feature, the product 'remembers' the state and mode that it was left in, in the advent of a power failure or if switched off. For example, if it was left in a safety mode, before power was interrupted, it will reboot in the safety state when switched back on.

The element is fitted with a dual temperature protection device, when the element surface reaches temperatures exceeding that of normal operation it will automatically shut off. This protects the element and the appliance from any damage.

Your Supatap appliance is fitted with a leak detection device. If a water leak is present, the system will shut down until the leak is resolved.

If the product malfunctions in any way isolate the electrical and water supplies immediately. Then contact either the installer, Supakwik or one of its authorized representatives.

General

For your convenience, your Supakwik Supatap has been programmed with many features developed over years of specializing in the industry, to offer simple, reliable trouble free service. For example, temperatures are not user adjustable. The appliance continually monitors atmospheric and water quality conditions and automatically adjusts the boiling temperature to deliver water at the best temperature possible, while generating no energy wasting steam.

Your Supatap is fitted with market leading patented "Energy Saving Features". The tap is equipped with sensors which continuously monitor your presence. Within 2 minutes of you using the product and vacating the room, your appliance enters power saving modes. Your appliance also '*learns*' how it is used and will step into deeper sleep modes in longer idle periods and will even power off automatically over weekends and overnight reducing your power bill dramatically. If however, you require boiling water at times you don't normally use the appliance, it will automatically sense your presence and return to normal operating state. These features constantly put the system into various levels of power saving modes continuously during the day and night, maximizing energy saving while negating the need for programmable timers or any user interference. Supakwik has patents to safeguard this market leading power saving technology.

The tap is robust and fit for duty intended. The Supakwik tap is not manufactured from plastics or inferior metals, but from high quality brass, chrome plated. It will stand up to the most demanding requirements. It includes LED's which will indicate the operating status of the appliance.

Normal Operation

To begin using the Supatap make sure the water and electrical supply are turned on. If you are using the Supatap for the first time please allow time for it to fill and heat, this process can take up to 20 minutes. The unit will not dispense boiling water until it has done so. During this time the tap may disperse steam.

Supatap

The Supatap comprises two levers capable of delivering - boiling, chilled and filtered water. Dependent on the particular model installed, will dictate which functions are available to the operator. At any point in time to stop the Supatap from dispensing water move the levers on the tap to the middle or central position.

The boiling water lever is located on the left while the chilled / ambient filtered lever is on the right.

The tap also incorporates three LED indicators – Boiling (red), Chilled/Filtered (blue) and a system status indicator (multi-colour).

The multi-colour status LED has the ability of displaying various operating states that the appliance enters i.e. various operating modes, power saving modes, safety lock out, filter condition and system faults. Under normal operating conditions the status LED will display a white, yellow, green or a blue light.

The following multicolour status LED light colours are listed below along with their operating modes:

- White light indicating no lock operating mode.
- Yellow light indicating a safety lock mode.
- Green light (on approach) indicating in a power saving modes.
- Blue Light indicating boiling water under temperature.
- Violet light periodically flashing indicates filter change required (refer filter change).
- Red light indicating fault conditions (refer fault conditions).

Listed below are the functions of the boiling and chilled/filtered LED's:

- Boiling water is available at any time when the boiling water LED is illuminated red.
- Chilled and or filtered water is available at any time when the chilled/filtered LED is illuminated blue.

Note: If the tank is emptied by drawing boiling water, delivery of boiling water will be inhibited for 45 seconds. This will be evident by the status LED displaying blue and the red boiling LED being off. Boiling water is not available during this 45 second period. Chilled/Ambient filtered levers will only deliver water for a 2 minute period. The lever must be returned to the OFF position before delivery will reoccur.

Boiling water will only deliver for 20 seconds at a time.

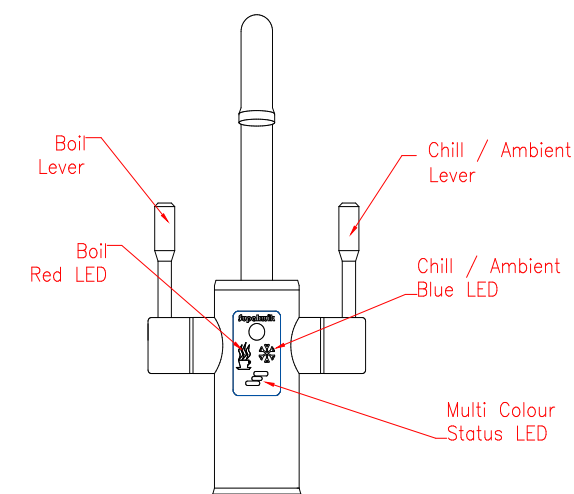

Appliance Operating Modes – Boiling Water

All models include a choice of 2 automatic safety lock modes or a no lock tap mode. These modes can be used in conjunction with the operational power saving feature turned ON, partially ON or OFF. Appliance default mode is NO lock - power saving features OFF.

SINGLE LEVER AUTOMATIC LOCK – In this safety operation mode the system is always in a locked delivery mode. To deliver boiling water, the boiling lever must first be pushed away from the operator and then brought forward. At any time while the status LED indicates white, boiling water may be dispensed. Approximately 5 seconds after the boiling lever is returned to the off position, the system will automatically enter the locked state. The status indicator will illuminate yellow.

DUAL LEVER AUTOMATIC LOCK – In this safety operation mode the system is always in a locked delivery mode. To deliver boiling water both the boiling and chill tap levers must be pushed away from the operator and held there until the status LED indicates white (approx. 3 seconds.) The levers must then be brought back to the 'Off' position. At any time while the status LED indicates white, boiling water may be dispensed by pulling the boiling water lever forward. Approximately 8 seconds after the boiling lever is returned to the off position, the system will automatically enter the locked state. This is visible by the status indicator illuminated yellow.

NO LOCK OPTION (default) – In this mode, boiling water is always available when pulling the boiling water lever forward. The status LED illuminates white.

POWER SAVING - TURNED ON – In this mode, the appliance enters the first level power saving mode the moment you vacate the room, by allowing the water temperature to reduce and remain at 88°C. Due to excellent insulation qualities, this will occur over a 1½ hour period without the heater element ever coming on. The moment the Supatap detects your presence it will immediately wake and return to operating temperature. Until such time as it reaches operating temperature the status LED will illuminate blue. This could take from 1 – 160 seconds dependent on capacity of the appliance and the time period that the appliance has been in this power saving mode.

POWER SAVING – ON PARTIAL In this mode, only the self-learning feature remains on. The Supatap will continue to switch off only in times of protracted non-use.

POWER SAVING - TURNED OFF (default) – In this mode the appliance remains at operating temperature at all times. User power saving feature is still available. (See page 7).

Operational Mode	Tap Safety Lever Operations			Power Saving		
	Single	Dual	Off	On	Partial	Off
Single Lever / Power Saving On	●			●		
Dual Lever / Power Saving Partial		●			●	
No Lock / Power Saving Off (Default)			●			●
Single Lever / Power Saving Partial	●				●	
Dual Lever / Power Saving On		●		●		
No Lock / Power Saving Partial			●		●	
Single Lever / Power Saving OFF	●					●
Dual Lever / Power Saving Off		●				●
No Lock / Power Saving On			●	●		

Modes are selected during bootup of the Supatap.

To select Tap Delivery Modes.

- Place both levers in the OFF position.
- Switch the Supatap ON
- Pull both levers forward.
- Wait for the Status LED to stop flashing.
- Push both levers backwards
- The status LED will now flash yellow, blue & white, alternatively.
- Bring both tap levers forward while flashing the colour of the tap operating mode you require. (white - no lock, yellow - single lever lock, blue - dual lever lock)
- Switch the Supatap OFF then ON again.

To select Power Saving Modes.

Turning the Power Saving Feature ON, partially ON or OFF

- Switch Supatap OFF.
- Place chill lever in the backward position.
- Switch Supatap ON
- Status LED will flash Green, Violet & Red
- Return chill lever to OFF position on desired mode (green-on, violet-partial, red-off).
- Allow appliance to boot, calibration & enter normal operation mode.

Note: Chilled and/or filtered water operations are not affected in the safety lock modes.

User Power Saving Feature (Domestic Appliance Only)

Your appliance includes a further user power saving feature. This feature is available at all times while the appliance is on irrespective of the operating mode selected.

There are times when only chilled or ambient water delivery is required and you know you will not be requiring boiling water for protracted periods. To prevent the appliance from wasting energy by continuously re heating whenever detecting your presence, place the 'boiling lever' in the backward position and leave it there. The red led will flash and then go off, the status led will go off. When you now approach the appliance, it will not reheat. Chilled / Ambient delivery is still available.

To return the Supatap to its prior operating mode, simply return the boiling lever to the OFF position.

Please remember if you have the 5 in 1 model, hot water will no longer be available after approximately 12 hrs.

Hot and Cold Water Mixer (5 in 1 model)



The hot and cold tap supplied with the heater has been specially designed for use with this appliance. The use of any other tap product will result in damage to the appliance and void warranty.

The Supatap 5 in 1 model incorporates hot and cold water delivery. The hot & cold water tap operates as per conventional kitchen sink mixer taps. The tap is marked accordingly.

When hot water is delivered, it can have the effect of temporarily reducing the boiling water temperature. If this occurs, the red LED on the boiling tap will be extinguished and boiling water will only be available once the status LED changes from blue to white once again.

Care & Maintenance

Cleaning

When cleaning the outer case of the appliance, care should be taken not to dislodge pipe work or electrical connections. Do not store items on top of this appliance. Do not wipe with abrasive solvents or pour water over this appliance.

This appliance tap is manufactured from brass which is chrome plated. Clean the tap with a damp cloth. Do not pour water over the tap. Avoid abrasive solvents and sponges when cleaning the tap.

Maintenance – Status LED flashes violet intermittently.

Filters and their replacement.

This appliance is fitted with a 5 micron canister filter cartridge complying with AS3487 located inside the front door. For poor water quality a ½ micron canister filter cartridges is available to suit this appliance. Filter life of the ½ micron cartridge is significantly less than that of the 5 micron cartridge. Filter life is based on the demand placed on the appliance, together with the quality of the water supply. The standard filter cartridge, under general demand should deliver a life expectancy of between 5 - 8 months or approximately 11,000 liters. The filter replacement default timer is set at 6 months. The appliance has an overriding control which monitors the volume and flow of water that passes through the filters. When the status indicator begins flashing violet intermittently the filter cartridge must be replaced. Failure to replace the filter will result in the appliance entering a failure mode and shut down.

Replacing the filter cartridge.

- Shut off the water supply, remove approximately two cups of boiling water then switch off the appliance. (this reduces the line pressure in the system)
- Open the front door, place a cloth below the filter (to absorb possible spills) and remove the filter by rotating anticlockwise and then pulling down.
- Dry up any water spills and fit new filter cartridge by inserting into the bayonet fitting and rotating clockwise.
- Open the water supply.
- Reset the filter indication by switching on the appliance and placing both tap levers in the backward position. When the status LED goes out bring both levers to the off position.
- Flush the new cartridge by delivering Ambient or Chilled water for 5 minutes.

After replacing filter cartridges, check all connections for leaks. Inspect the base of the unit and cupboard for water or leaks.

When replacing filter cartridges, use only genuine filters specifically designed for this appliance. For assistance with filter replacement or where to purchase replacement cartridges, please contact your local agents, Supakwik or visit our website at www.supakwik.com.

Changing the filter default time period.

In applications of very low demand i.e. domestic applications, or areas of particularly good water supply quality, it is possible to change the default time period which initiates filter replacement (see maintenance mode). The appliance control monitoring water volume and flow through the product can't be changed.

1. Warranty, Terms, and Conditions

- 1.1 Our goods come with guarantees that cannot be excluded under the Australian Consumer Law. You are entitled to a replacement or refund for a major failure and compensation for any other reasonably foreseeable loss or damage. You are also entitled to have the goods repaired or replaced if the goods fail to be of acceptable quality and the failure does not amount to a major failure.
- 1.2 Supakwik Water Heaters Pty. Ltd. guarantees your heater against faulty manufacture or mechanical defect for the period as stipulated below:
 - 2 Years warranty – The first 12 months parts and labour, the following 12 months parts only.
- 1.3 Supakwik reserves the right to choose whether to:
 - a. Repair the product,
 - b. Replace the product or part with an equivalent, or
 - c. Refund the cost of the product.
- 1.4 After a product has been repaired or replaced under warranty, the product will still be under warranty for the remaining warranty period.
- 1.5 Filters are not covered under warranty as their lifespan is dictated by the quality and quantity of the water that passes through it.
- 1.6 The unit must be installed in accordance with the local water & electrical supply authority regulations, to be eligible for warranty.
- 1.7 The unit must be operated and maintained in line with “Care and Cleaning” instructions to be eligible for warranty.
- 1.8 The warranty claim must be made within the warranty period to be eligible.
- 1.9 The warranty period commences from the date of purchase.
- 1.10 If Supakwik is engaged to replace or repair a product under warranty, and there is no fault or the fault is found to be ineligible for a warranty claim, the claimant will be liable for all the costs involved, it will then be their choice whether or not to go ahead with repairs.
- 1.11 This warranty is not transferable and only applies to the original owner.
- 1.12 This warranty is only valid within Australia.

2. Warranty Exclusions:

- 2.1 This warranty does not exclude, limit or modify any warranty condition obligation or liability which is or may be implied or imposed on the company by virtue of the Australian Consumer Law, or any other statute, rule, or regulation except for the extent to which the company is lawfully entitled to exclude limit or modify it.
- 2.2 Supakwik Water Heaters Pty Ltd is not liable:
 - a. For the cost of removal, shipping, and or reinstallation of a product or part that needs to be repaired or returned to Supakwik Water Heaters.
 - b. For the cost of travelling to and from a location, to repair or replace a product or part.
 - c. For attempted repair or damage by unauthorised service people.
 - d. If malfunction or damage is caused to a part or product due to lime Scale, dissolved mineral build up, or sediment as a result of poor water quality.
 - e. If the water supply is non potable.
 - f. If any modifications or third party parts are fitted, this includes filters.
 - g. If the product is used for which it was not designed or intended.

- h. Unless the product has been installed as per the installation instructions supplied with the product.
- i. Unless the product has been installed by a person licenced to do so.
- j. If the product or part has been damaged due to:
 - (i) Misuse or abnormal use.
 - (ii) Accidental damage.
 - (iii) Neglect.
 - (iv) Acts of God, such as cyclones, lightning strikes, flooding etc.
 - (v) Continued use after the fault has become apparent.
- k. If the serial number or rating label, which identifies the product has been removed or tampered with.
- l. For additional costs involved to access products.
- m. For general wear and tear.
- n. Damage that occurred during transport.

How to make a warranty claim

If you have a product that you feel meets the requirements above and has become faulty please contact Supakwik via email at services@supakwik.com or phone (07) 3800 0575. Supakwik must be contacted before any works have commenced on a product, or is returned to us for repair or replacement under warranty. Failure to comply may result in the warranty void.

Supakwik Water Heaters
3/7 St Jude Ct,
Browns Plains, 4118,
Queensland.

Product Support

Once again, thank you for choosing the Supakwik Supatap. Your product is designed and manufactured in Australia utilizing the highest quality food grade materials, processed through automated plant and assembly processes, guaranteeing quality.

Supakwik prides itself on excellent product support. If you ever need product assistance with your appliance, a call to Supakwik will not be answered by a recording with multiple selections, but by a real individual, whom will give you direct access to one of the engineers who designed your appliance. That's the type of support you can expect!

A Supakwik member or one of its approved service agents will always be on hand to assist with any service requirements you may have. Call (07) 3800 0575

Alternatively, visit our web site at www.supakwik.com

Installation instructions

Thank you for recommending the Australian made Supakwik Supatap.

This unit must be installed by a qualified person in accordance with AS3498 AS/NZS603350.2.15, AS/NZ3500.4 and all other local plumbing, electrical, and building Regulations.

Inspect the unit and its contents and ensure there is no damage to the product before proceeding with the installation, failure to do so may result in the product malfunctioning.

Contents

- Undersink appliance.
- Chiller appliance (optional).
- Two lever Supatap.
- Sink tap (5 in 1 models).
- 32mm back nut & spacer.
- Counter Top Seal.
- Filter cartridge.

Supatap Installation

Positioning

This appliance is intended to be connected to a potable water supply and for indoor use only; the appliance casing is not waterproof. Intended positioning is within a dry cupboard space below the sink. Consideration must be given to the location of the appliance and tap prior to installation, such that all installed pipe work from the tap has a continuous fall to the unit. It must be installed in an upright position with all pipe connections to the rear wall of the cupboard. The main heater must be positioned no less than 25mm from both the rear and side wall of the cupboard. When installed with the chiller unit, the chiller unit is to be positioned such that a 50mm clearance exists on all sides of the chiller. Cupboard door spaces are to be fitted.

Electrical Services

A standard single 3 pin 10 Ampere GPO is required, that provides 240 V AC at 50 HZ. For models that include a chilled water function a dual 3 pin 10 Ampere GPO is required. It is recommended that a dedicated supply be provided, protected with an approved earth leakage device. Please isolate power supply when removing the jacket cover. Once the jacket cover is removed you will expose live wiring.

Filter Installation

Filters must be flushed as per filter label instructions prior to fitment.

A bayonet style canister filter complying with AS3497 is supplied with this appliance. This filter must be fitted to the Supatap. The filter is fitted in the front of the appliance by opening the front door. Remove the sealed wrapper from the filter cartridge. Fit the cartridge by inserting into the holder and rotating anti-clockwise by a ¼ of a turn. Pull down on the cartridge to check that it is securely fitted.

NOTE: Do not install any additional pressure limiting valves or filters before or after water supply line to the Supatap or chiller.

Water Supply

The water supply to the unit must be cold potable water within a pressure range of 80 - 1000kPa and a temperature range of 5 – 35°C.

Models without a separate hot and cold mixer require a single 15mm (½”) cold water supply. Models with a separate hot and cold require a dual 15mm (½”) cold water supply. Supplies must have an isolating valve installed in a suitably accessible location, and within 500mm from the inlet to the appliance. The appliance includes a pressure limiting and backflow prevention device, therefore one is not required.

Before connecting the water supply to the Supatap, the supply line must be flushed thoroughly. Connect a flexible pipe to the outlet of the isolation valve (located within 500mm of the Supatap), and flush the water into an appropriate container. This is to ensure no dirt or swarf passes into the appliance.

Connect the cold water supply to the Supatap male thread marked “INLET” using a stainless steel braided flexible 15mm (1/2”) pipe.

NOTE: Pay particular attention not to allow water into the tap electrical connector.

Supatap Tap Installation

Boiling, Chilled, Filtered Water Tap

This tap is designed to suit bench tops with a thickness of 0.5mm to 50mm thick. Position the tap in its desired location and mark out a 35mm hole where the tap is to be installed.

Note: The retaining nut has a diameter of 52mm, therefore it is recommended that the center of the hole be at least 28mm clear of the bowl or cabinet edge to ensure that there is sufficient clearance to fit the tap retaining nut. Before cutting through the bench top make sure nothing is obstructing the path of the cutting tool or tap on the underside of the bench top. Remove any burring or loose timber from either side of the 35mm hole. Ensure the washer is in place on the underneath side of the tap base and then slide the piping and base of tap through the hole. Slide all piping and cable through the spacer and 32mm flanged back nut. Slide the spacer & nut up to the tap and tighten the nut until the tap is secured firmly on the bench top. Once the appliance is in the desired position and the Supatap is installed you can connect the services from the tap to the appliance.



WARNING: Do not use the tap handles to rotate the tap when tightening the retaining nut. This will result in damage to the tap.

To prevent ingress of foreign matter, a disposable length of silicone tube joins the boiling outlet and the heater vent. This must be removed and discarded before installation.

Connections for BF Series – Boiling / Ambient Filtered (2 in 1 models):

Boiler / Filtered Tap

- Tap tube with red band, connect to fitting marked “BOILING”.
- Tap tube with black/no band, connect to fitting marked “VENT”.
- Blue tap tube to be connected to fitting marked “FILTERED”.
- Tap electrical connector to 6 pin socket (this connector is polarized and can only be connected one way).

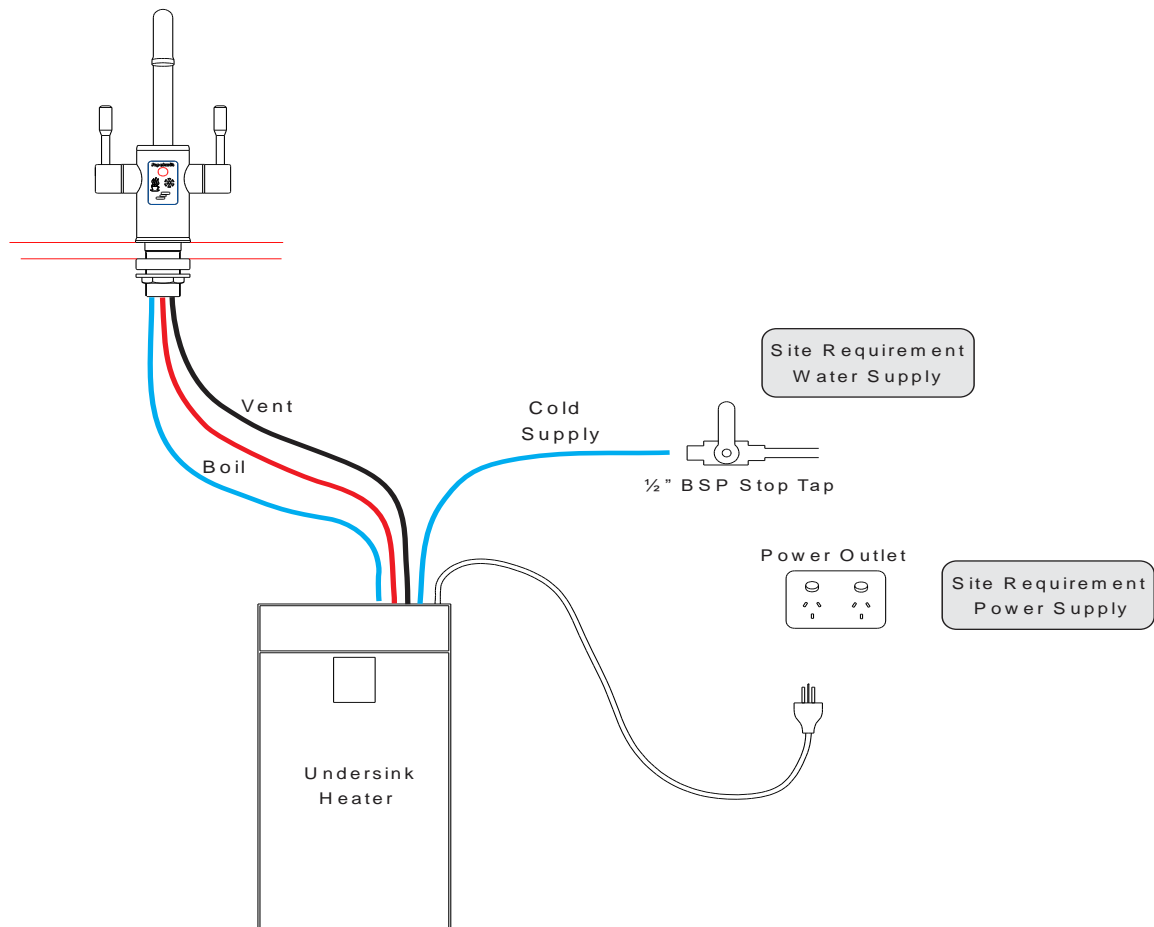

WARNING: The silicone piping from the Boiler/Chiller/Filtered tap to the appliance must have a continuous fall to prevent the pipes from trapping water, twisting or folding. Failure to comply with this warning will cause the appliance to malfunction and void warranty. You may need to cut the piping to achieve the length required for a continuous fall.

NOTE: If a third party chiller is to be installed on the 2 in 1 models, then the “FILTERED” fitting on the appliance is to be connected to the inlet of the chiller. The blue tap tube is to be connected to the outlet of the Chiller. Chillers must comply with AS3498.

The filtered function of the Supatap appliance then becomes chilled.

Connections for BC Series – Boiling / Chilled (2 in 1 models):

Boiler / Chilled Tap

- Tap tube with red band, connect to fitting marked “BOILING”.
- Tap tube with black/no band, connect to fitting marked “VENT”.
- Blue tap tube to be connected to the chiller “OUTLET”.
- Blue tube to be connected from heater “FILTERED” to chiller “INLET”.
- Tap electrical connector to 6 pin socket (this connector is polarized and can only be connected one way).

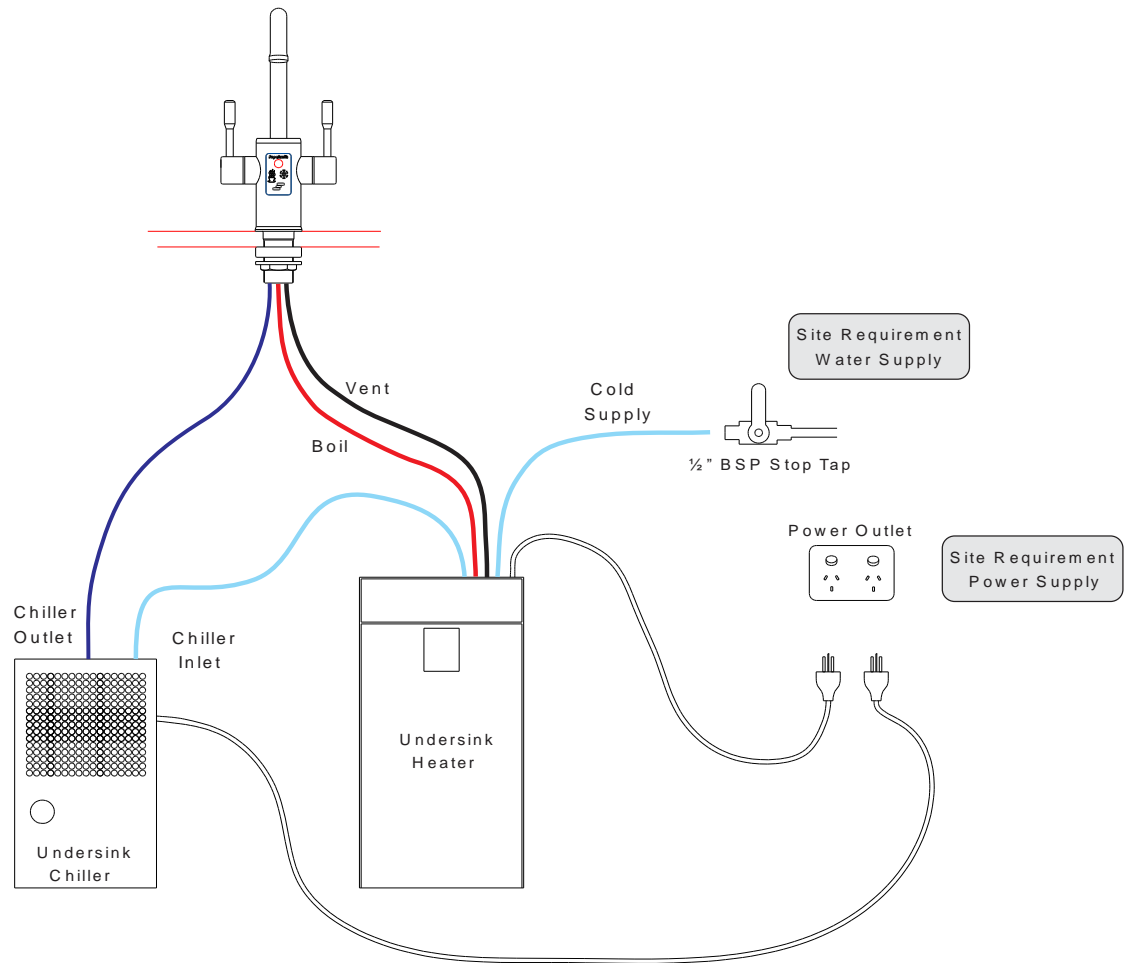

WARNING: The silicone piping from the Boiler/Chiller/Filtered tap to the Supatap must have a continuous fall to prevent the pipes from trapping water, twisting or folding. Failure to comply with this warning will cause the appliance to malfunction and void warranty. You may need to cut the piping to achieve the length required for a continuous fall.

Connections for 3 in 1 models:

Boiler / Filtered Tap

- Tap tube with red band, connect to fitting marked “BOILING”.
- Tap tube with black/no band, connect to fitting marked “VENT”.
- Blue tap tube to be connected to the outlet of the John Guest Y connector.
- Filtered out to inlet of the John Guest Y connector.
- Chiller out from the appliance to inlet of the chiller.
- Chiller outlet to remaining inlet of the John Guest Y connector.
- Tap electrical connector to 6 pin socket (this connector is polarized and can only be connected one way).

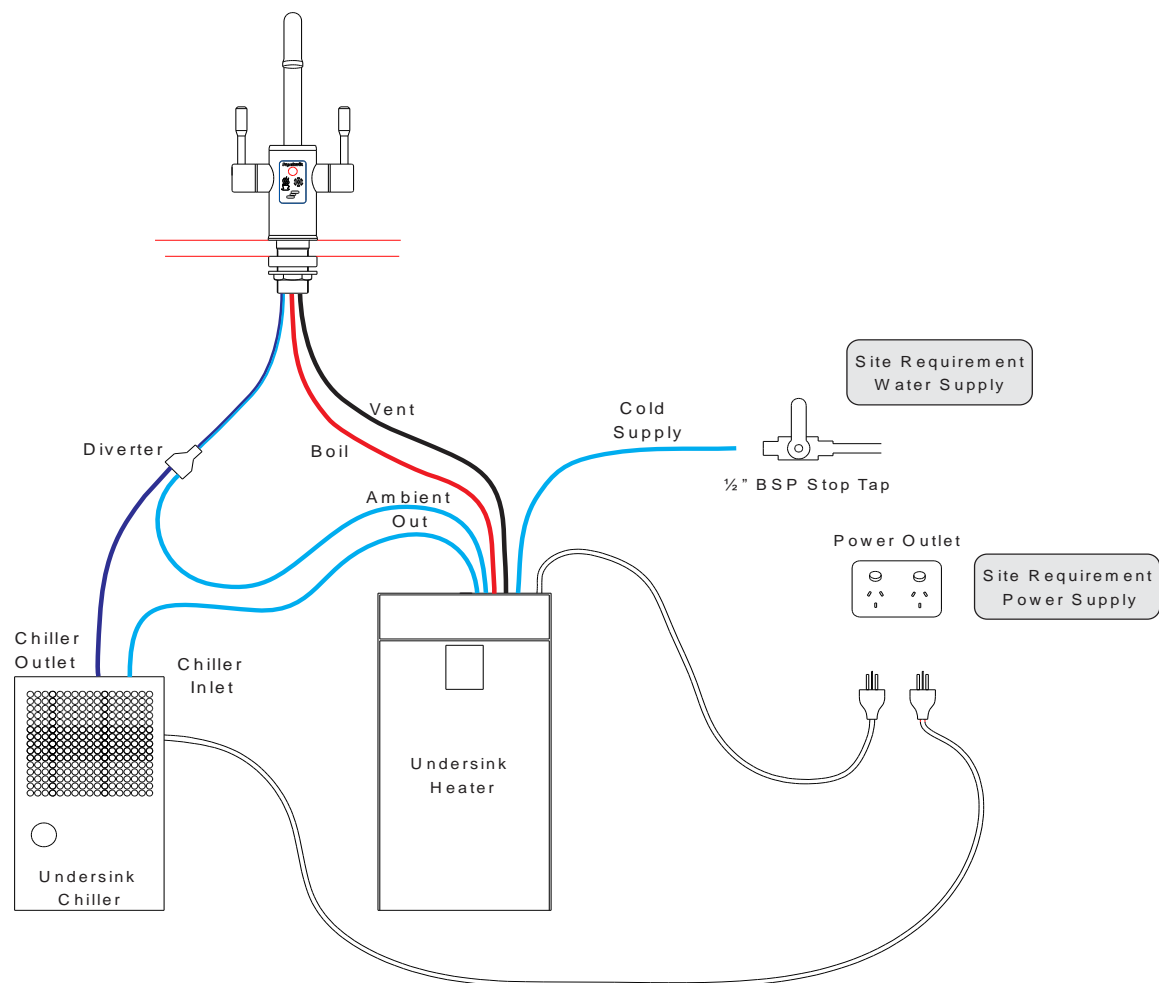

WARNING: The silicone piping from the Boiler/Chiller/Filtered tap to the Supatap must have a continuous fall to prevent the pipes from trapping water, twisting or folding. Failure to comply with this warning will cause the appliance to malfunction and void warranty. You may need to cut the piping to achieve the length required for a continuous fall.

NOTE: If a Third party chiller is **NOT** to be installed on the 3 in 1 models, then the blue chiller supply pipe from the appliance must be connected to the “INLET” of the John Guest Y Diverter connector. Chillers must comply with AS3498.

Connections for 5 in 1 models:

Boiler / Chiller / Filtered Tap & Hot/ Cold Tap

- Tap tube with red band connect to fitting marked “BOILING”.
- Tap tube with black/no band connect to fitting marked “VENT”.
- Blue tap tube to be connected to the outlet of the John Guest Y connector.
- Filtered out to inlet of the John Guest Y connector.
- Chiller out from the appliance to inlet of the chiller.
- Chiller outlet to remaining inlet of the John Guest Y connector.
- Tap electrical connector to 6 pin socket (this connector is polarized and can only be connected one way).

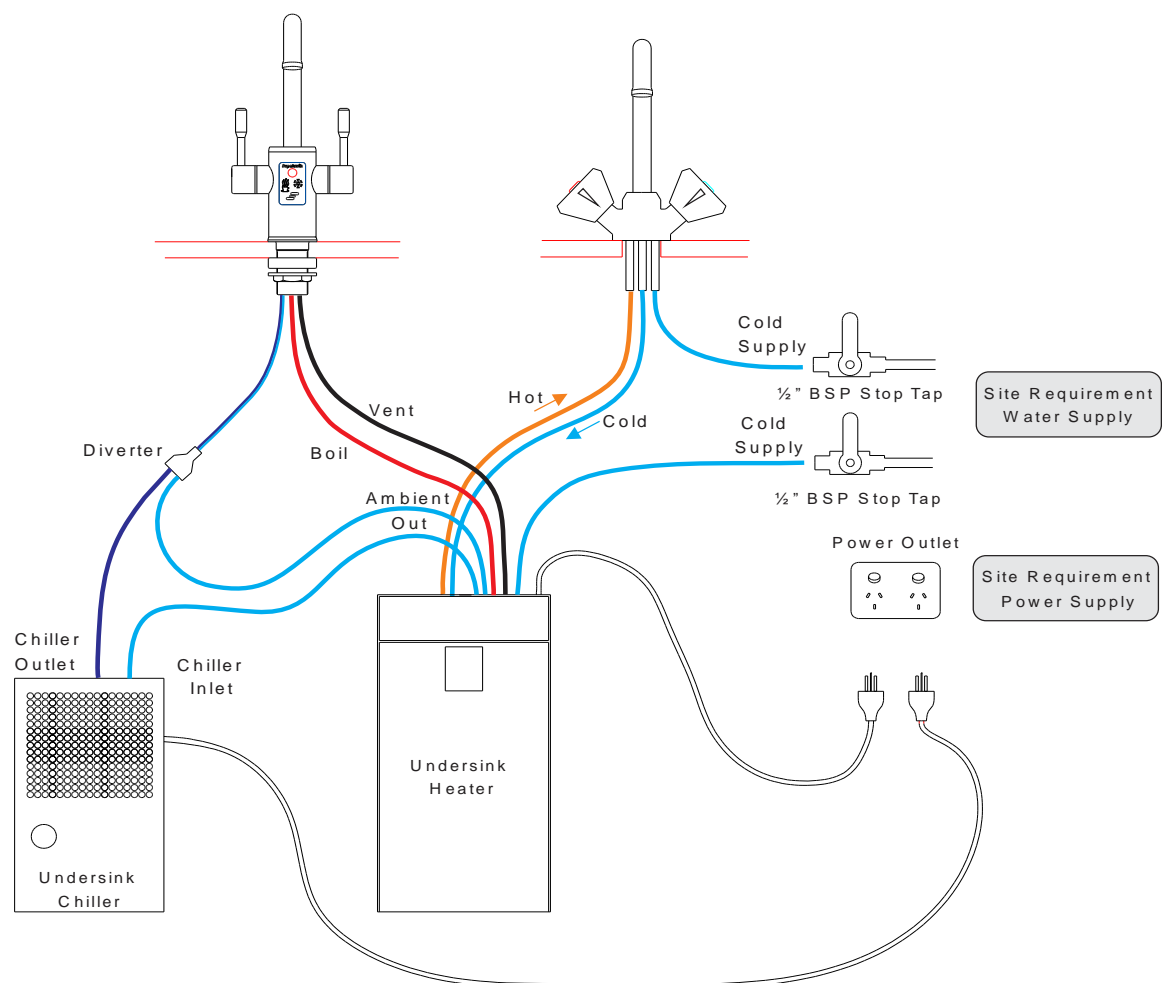

WARNING: The silicone piping from the Boiler/Chiller/Filtered tap to the Supatap must have a continuous fall to prevent the pipes from trapping water, twisting or folding. Failure to comply with this warning will cause the appliance to malfunction and void warranty. You may need to cut the piping to achieve the length required for a continuous fall.

NOTE: If a Third party chiller is **NOT** to be installed on the 3 in 1 models, then the blue chiller supply pipe from the appliance must be connected to the “INLET” of the John Guest Y Diverter connector. Chillers must comply with AS3498.

Hot and Cold Mixer Tap

The flexible tap hose marked with a blue arrow pointing towards the tap is to be connected to the cold water supply. Please note that these connections are all 3/8” fittings. An approved Dual Check pressure relief valve complying with WaterMark requirements for use in Australia and IEC 61770 for use in EU countries must be fitted (not supplied) between the cold water supply and this tap connection.

A discharge pipe connected to the pressure relief device is to be installed in a continuous downward direction in a frost free environment.

The flexible tap hose marked with a blue arrow pointing away from the tap is to be connected to the fitting marked “HOT IN” on the appliance.

The flexible tap hose marked with a red arrow pointing towards the tap is to be connected to the fitting marked “HOT OUT” on the appliance.

Commissioning and Testing

Every Supatap appliance is wet tested before it leaves the factory to ensure you receive a fault free product.

Once the installation is complete, position both tap handles in the OFF position. Using the isolating valve(s) turn the water on slowly. Check over the entire product for water leaks, if there are no leaks turn on the electrical power supply to the Supatap. The unit will boot up in the default mode and begin to fill slowly, during this process monitor the Supatap for any water leaks.



NOTE: Do not turn ON the power supply to the chiller until the chiller has been purged of air. As the heater appliance controls the water supply to the chiller, purging cannot be undertaken until the heater has calibrated and entered the operating mode.

While the unit is filling to low level the status indicator will flash blue. On reaching low level, heating and filling will commence. (Boiling LED flashes red, status LED flashes blue). On reaching high level, (boiling & status LED will be ON) the appliance will automatically calibrate. After calibration, the status LED will change to white and the red and blue boiling and ambient/chill LED indicators will be on, indicating that the appliance is ready for use.

Where a chiller is fitted, purge the chiller by opening the cold water tap. The chiller is correctly purged when the water supply stops immediately the tap is switched off. Once purged, plug the chiller into the power supply and switch on.

Perform the following tests below to ensure the Supatap is functioning correctly:

- On first fill, the pump may require priming to remove trapped air. Pull the boiling lever forward for 1 – 2 seconds and then return to off position. Repeat this step until boiling water flows correctly from the tap.
- To dispense boiling water gently pull the boiling lever towards you.
- To dispense chilled water gently pull the right lever towards you to the “CHILLED” position marked on the side of the tap.
- To dispense filtered ambient water gently push the right lever away from you to the “FILTERED” position marked on the side of the tap (3 in 1 model or above).

Maintenance Mode

The appliance can be put into a maintenance mode to allow for the testing of various components, together with changing filter change trigger time. This should only be undertaken by trained service agents.

Placing the appliance into the Maintenance Mode.

- Switch the appliance OFF.
- Switch the appliance ON and while the status LED is flashing pull both levers forward simultaneously.
- When the status LED goes off push both levers to the full backward position simultaneously and then to the OFF position. The Status LED will now flash white.

The appliance has now been placed in the maintenance mode. To exit maintenance mode, restart the appliance using the power switch.

Changing the filter replacement default timer.

- Place the appliance into the maintenance mode.
- Pull both Boil and Chill levers to the forward position simultaneously.
- The Status LED will now begin flashing green. Each ON flash represents one month to filter change trigger point.
- Count the months required to trigger filter replacement and on the interval after the desired count place both levers in the OFF position. The Status LED will now flash White. The filter replacement trigger point is now set at the desired months.
- Switch the appliance OFF and ON again and allow to reboot.

Although the LED will continue flashing past the count of 12, the filter replacement trigger point can only be set between 1 and 12 months. If the flash count passes 12 flashes and the levers are placed in the OFF position the filter change trigger point will be 12 months.

Note: To change the desired months, simply pull both levers forward again, while in the maintenance mode and the count will restart.

Returning the appliance to Normal Operating Mode.

- Switch the appliance OFF.
- Place both levers in the NEUTRAL position.
- Switch the product ON.
- Appliance will now reboot in Normal Mode

Rebooting.

During the reboot phase, the Status LED will initially flash the two colours representing the safety lock and power saving mode. It will then proceed to flash the counts of filter change trigger months. The two colours of the filter count period months represent used and remaining.

For further information on this operation mode contact Supakwik Service Department on +61 (07) 3800 0575.

General Product Specifications

Model	BF(C) Series	BF(C) Series	BCF Series	BCFHC Series
Boiler Capacity	2 - 4 Litre	6 Litre	4 - 6 Litre	6 Litre
Hot Capacity	NA	NA	NA	10 Litre*
Ambient	Yes	Yes	Yes	Yes
Chilled	Optional*	Optional*	Yes	Yes
Filter	5 Micron	5 Micron	5 Micron	5 Micron
Voltage	240V AC	240V AC	240V AC	240V AC
Element Wattage	2400W	2400W	2400W	2400W
Supply Connection	15mm	15mm	15mm	15mm
Water Supply	80-1000kPa	80-1000kPa	80-1000kPa	80-1000kPa
Back Flow Prevention	Dual Check	Dual Check	Dual Check	Dual Check
PLV	350kPa	350kPa	350kPa	350kPa
Dimensions:				
Height	340 mm	395 mm	395 mm	395 mm
Width	190 mm	190 mm	190 mm	190 mm
Depth	410 mm	410 mm	410 mm	410 mm

Weights

Appliance Dry

Appliance Wet

* If a chiller is fitted to the BF models, ambient filtered water is no longer available. Model number then becomes BC.

* Hot water is delivered at approximately 65°C. After using hot water, boiling water delivery may be temporarily suspended.

Trouble Shooting

Appliance tap status LED flash sequences in red.

Fault Description	Flash Code		
Fill Error - Empty to Low Probe	2		
Fill Error - Low to High Probe	2		
Leak Detection	3		
Heating Failure	4		No temp rise in 1½ minutes.
Pump Error	1	4	
Positive / Negative Heat Excursion	1	5	Over / Under Heat.
Bottom Probe Failure	2		
Top Probe Failure	2		
Vent Thermistor Open circuit	2	3	
Vent Thermistor Closed circuit	2	4	
Tank Thermistor Open circuit	2	5	
Tank Thermistor Closed circuit	2	6	
Fatal Filter Failure	2	7	
Continuous Boil Protection	3	4	
Communication Error	1	2	
Eprom Error	1	3	



(07) 3800 0575

sales@supakwik.com

supakwik.com