

Supaflush

Urinal Water Saver Installation Instructions and User Guide



Features:

- Rust Free Sensor Housing
- Normal Operation Indicator
- Low Battery Indicator
- Long Life Enclosed Unit – Reduces Moisture & Dust Exposure
- Simple & User Friendly
- 9 volt Power Supply - Large Capacity Battery
- Installation Kit
- 2 year Warranty



Contents

• General Description	3
• Sensor Location	4
• Sensor Mounting	6
• Plumbing	6
• Connecting the Valve	9
• Connecting the Battery	9
• Standby Condition	9
• Reconfiguring Supaflush Settings	10
○ Pre Flush	10
○ Sanitary Flush	10
○ Flush Duration	10
○ Flush Delay	11
• Care, Cleaning, Battery, & Maintenance	13
• Troubleshooting	14
• Spare Parts & Accessories	15
• Warranty	16
• Latching Valve Diagram	19

Supaflush Water Saver

Package includes:

- Installation Instructions & User Guide
- Sensor Assembly
- Battery Pack or Mains Power Supply
- Sensor to Solenoid Valve Cable
- Solenoid Valve (kit only)
- ½" Ball Valve (kit only)
- 2 x ½" Compression Fittings (kit only)
- ½" Strainer (Kit only)



IMPORTANT

These water saving devices must be installed by suitably qualified persons in compliance with AS3500.2 Warranty will be void if Installation Instructions are not followed.

General Description

An automatic urinal flushing system, available in a ceiling and wall mounted, battery or mains powered configurations. Designed for indoor use only.

The system consists of a sensing unit operating a 9 volt solenoid valve. A visible LED indicates sensing, flushing, countdown to flush (delay) and battery condition.

When the sensor is triggered through motion, a 2 second pre-flush will commence, once complete a 2 minute timer will then start (delay). When the timer times out the solenoid valve will open for 10 seconds (flush time). These settings can be individually customised to suit the needs of the installation.

This User/Installation Guide applies to both ceiling and wall mounted systems. As the wall mounted system can have many unique install configurations, this guide will concentrate on the installation for the ceiling model only.

Sensor Location

You will need to determine the quantity and location of the urinals or troughs that will be serviced by the sensor.

The area that the sensor can cover is approximately 3 metres x 1 metre, see **Figure 1**.

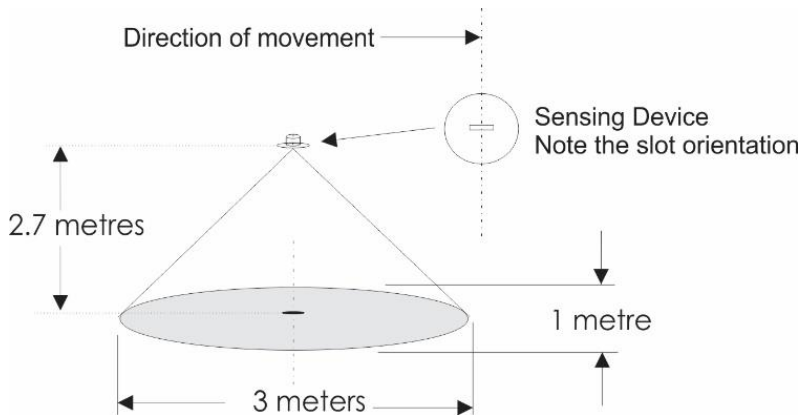

Figure 1

The Sensor should be positioned approximately 1 metre away from the centre point of the urinal or trough installations with the slot in the sensor housing at 90 degrees to approaching traffic where possible, see **Figure 2 and 3**.

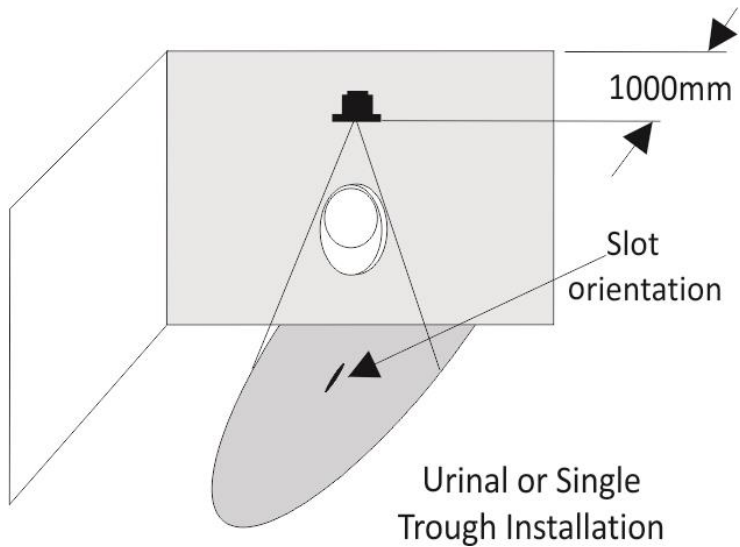

Figure 2

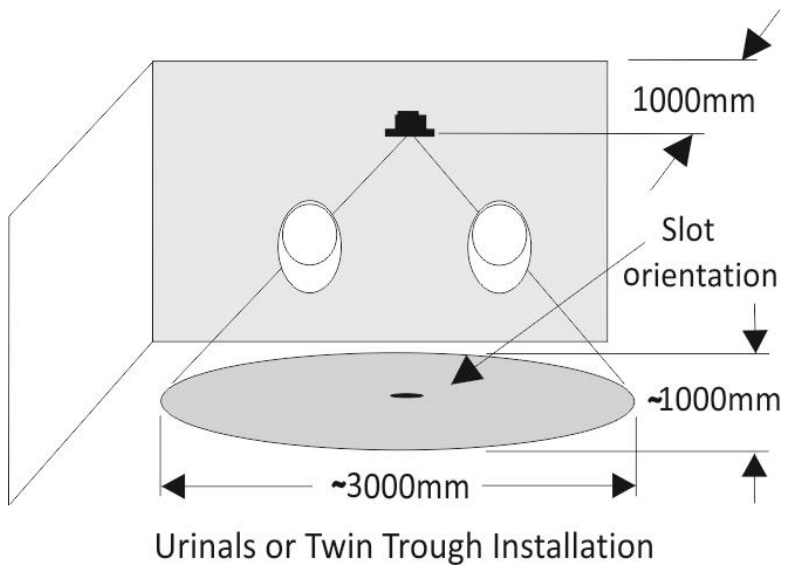

Figure 3

Sensor Mounting



IMPORTANT

On deciding the sensor position, before cutting the 100mm hole in the ceiling be sure to check for possible electrical or plumbing services or any other obstruction above the ceiling.

Cut a 100mm hole in the ceiling. This will accommodate the sensor housing. The sensor housing is inserted in the same manner as a standard down light fitting.

Plumbing



IMPORTANT

The water supply must be between 100kPa – 700kPa.

Turn off the water supply and fit the isolating valve and solenoid valve. Be sure to note the flow direction of the valves, if installed back to front they will not operate. The solenoid valve can be mounted up-side down if required.

The solenoid valve must be installed no more than 2 metres away from the sensor unit, the cable supplied that connects the solenoid valve to the sensor unit is only 2 metres long.

The solenoid valve must be installed after the isolating valve, the strainer must be before the solenoid valve. **See Figure 4**

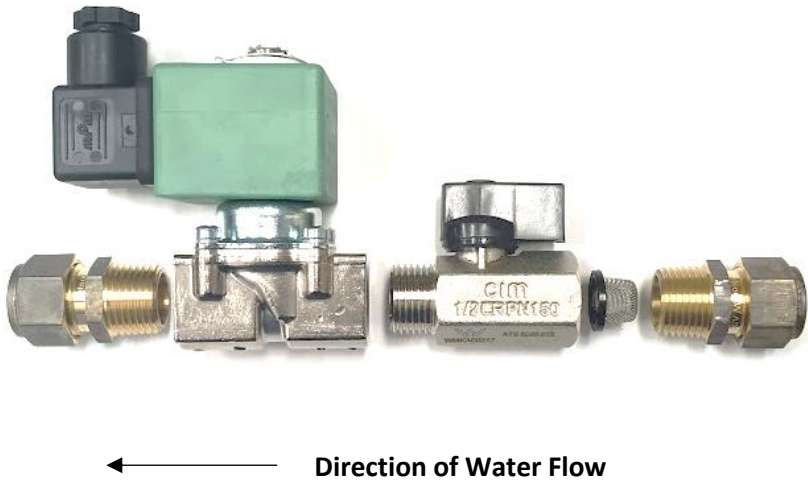

Figure 4

There must be an air gap of at least 25mm between the water supply and the sparge pipe or cistern maximum fill level/overflow pipe, this is to stop backflow from occurring.

To achieve this an air break must be installed vertically in a direct feed installation. For an installation where a cistern is used, the water supply inlet must be installed at least 25mm above the overflow pipe of the cistern, see **Figure 5**.

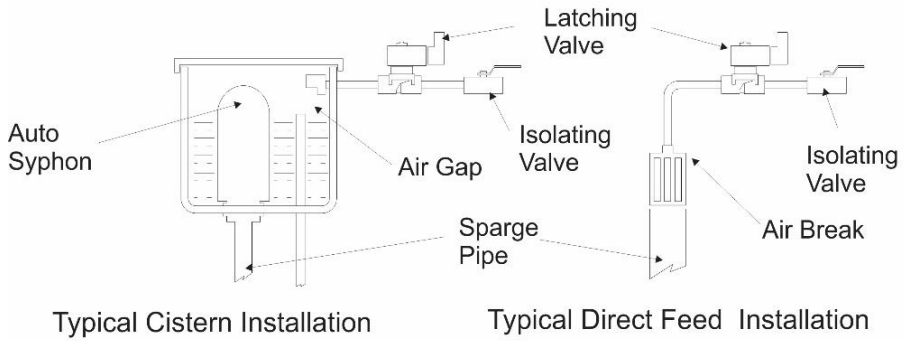

Figure 5



IMPORTANT

Ensure the valves are mounted in a position that is easily accessible for servicing. Care must be taken to ensure that no sealing tape enters the water supply ways as this will result in solenoid valve failure.

Connecting the valve to the sensor assembly

The sensor can only operate one solenoid valve.

Before connecting the valve cable to the sensor assembly ensure that the wires are installed correctly. When the screw heads of the connector are facing you, the wire on the left is brown and the wire on the right is blue.

See Figure 6.



Using the cable supplied, the sensor must be connected to the solenoid valve. This cable is 2 meters long. If a longer cable is required, contact the manufacturer on the details supplied on the back of this manual.

NOTE: Warranty will be void if this cable is altered. Consult the manufacturer if the cable needs to be altered.

Figure 6

Connecting the battery

Remove the battery cover at the rear. Remove the battery from its location and connect. Replace the battery and cover.

The LED will flash green and red when power is connected for approximately 60 seconds during the boot up process.

NOTE: Warranty will be void if the battery cover is not replaced. This cover prevents moisture and dust from entering the system.

Standby Condition

During standby mode i.e. when the system has not detected movement the LED will flash Green once every 10 seconds.

Reconfiguring the Supaflush settings



IMPORTANT

THE DIP SWITCH SWITCHES DO NOT ADD TO ONE ANOTHER, ONLY ONE PER SWITCH CAN BE IN THE OPPOSITE DIRECTION TO THE REST.

The default settings of the Supaflush is a 2 second pre flush, 2 minute delay, 10 second flush with a 24 hour sanitary flush.

To alter these settings, remove the battery cover and battery to expose the dip switches, see **Figure 7**.

Pre Flush Dip Switch

If pre flush is selected on, the solenoid valve will open for 2 seconds immediately upon motion detection. The pre flush duration is not adjustable.

Available options - On or off, see **Figure 7**.

Sanitary Flush

A sanitary flush will occur regardless if motion is detected or not, it will countdown the time selected and flush for the flush duration.

The sanitary flush duration is not independently adjustable to the flush duration. The programmed time for the flush duration will be the duration of the sanitary flush.

Five options are available – Off, 6, 12, 18 & 24 hours, see **Figure 7**.

Flush Duration

Flush duration is the time that the solenoid valve will remain open for once the delay timer has timed out. On completion of flush duration the LED will flash green for 1 minute (during this time sensing is disabled) before re-entering standby mode. This is to prevent the sensor from being triggered by the water that has been flushed.

Customizable between 3 seconds - 5 minutes. The sensor must have power to modify the flush duration setting.

To set the duration of the flush time hold down the flush duration button for 3 seconds, the LED will start flashing green rapidly. Release the button to open the solenoid valve and begin the timer, the LED will flash red.

To close the solenoid valve hold down the button again for 3 seconds, the LED will start flashing green rapidly. Release the button to close the solenoid valve and stop the timer. The time that the valve was open for will be stored as the Flush duration. Repeating this process will reset the previous setting. See **Figure 7**.

New settings will only take effect after the next flush cycle.

Flush Delay

Flush delay is the countdown until it flushes (valve opening) after motion has been detected, the LED will flash green once every 2 seconds for the duration of time selected on the dip switch setting.

There are several different delay time options available – 1,2,3,5,10,30 minutes, or 1,2,3,4,5,6 hours. One time can only be selected, see **Figure 7**.

Note: After reconfiguring the Supaflush and reconnecting the power, wait approximately 60 seconds before checking detection and operation.

Pre Flush Settings

On Off

on off

Sanitary Flush Settings

6 12 18 24

6 12 18 24

6 12 18 24

6 12 18 24

Off

6 Hour

12 Hour

18 Hour

24 Hour

Start / Stop

Flush Duration

1 2 3 5 10 30

Min Hrs

1 2 3 4 5 6

Flush Delay

2

Flush Duration Settings



Hold the flush duration button down for 3 seconds then release to start the flush duration.
Hold the flush duration button down for 3 seconds then release to stop the flush duration.

Flush Delay Settings

1 Minute

Min 1 2 3 5 10 30

Hrs 1 2 3 4 5 6

2 Minutes

Min 1 2 3 5 10 30

Hrs 1 2 3 4 5 6

3 Minutes

Min 1 2 3 5 10 30

Hrs 1 2 3 4 5 6

5 Minutes

Min 1 2 3 5 10 30

Hrs 1 2 3 4 5 6

10 Minutes

Min 1 2 3 5 10 30

Hrs 1 2 3 4 5 6

30 Minutes

Min 1 2 3 5 10 30

Hrs 1 2 3 4 5 6

1 Hour

Min 1 2 3 5 10 30

Hrs 1 2 3 4 5 6

2 Hours

Min 1 2 3 5 10 30

Hrs 1 2 3 4 5 6

3 Hours

Min 1 2 3 5 10 30

Hrs 1 2 3 4 5 6

4 Hours

Min 1 2 3 5 10 30

Hrs 1 2 3 4 5 6

5 Hours

Min 1 2 3 5 10 30

Hrs 1 2 3 4 5 6

6 Hours

Min 1 2 3 5 10 30

Hrs 1 2 3 4 5 6

DE11347B001

Figure 7

Care and Cleaning

The sensor assembly must be kept clean and dry, the slot must always remain free from dirt or anything else that can hinder the product from operating correctly. Use a damp cloth only to wipe away any dirt from the product, cleaning products can damage the product.

Battery



IMPORTANT

The 9 volt battery that we supply with this product has a much larger capacity when compared to a standard 9 volt battery. This is to ensure a longer battery life, if a standard 9 volt battery is used with this product operation time will be significantly reduced.

The battery life will be determined by the amount of flushes that occur, on average the battery should last in excess of 1 year. It is recommended that the system is regularly checked to ensure trouble free operation.

When the battery power is low the LED will flash red continuously, at this point the battery must be replaced. Failure to replace the battery may result in the valve not closing, resulting in a continuous flush.

Maintenance

If a filter or valve is installed to prevent dirt from causing the solenoid valve to malfunction they must be serviced or replaced regularly to ensure the valve remains operating.

Troubleshooting

Problem	Cause	Solution
	No power	Replace battery/check power supply
	Faulty sensor unit	Replace sensor unit
	Faulty solenoid valve	Replace solenoid valve
Solenoid Valve not opening	No water	Check that water supply is on
	Obstructed sensor	Clean sensor slot/remove obstruction
	Incorrect valve direction	Correct the valve direction of flow
	Water pressure	Make sure water supply is 100-700kPa
	Valve cable not connected	Connect valve cable to sensor
Solenoid valve not closing	No power	Replace battery/check power supply
	Faulty solenoid valve	Replace solenoid valve
	Flush time set too long	Set flush time shorter
Red LED Flashing continuously	Low power battery	Replace battery/check power supply
	Valve polarity is incorrect	Swap valve wire positions on connector
	Faulty sensor unit	Replace sensor unit
Condition	LED Status	
Standby	Green LED flashes once every 10 seconds	
Delay countdown	Green LED flashes once every 2 seconds	
Sensor Inhibited	Green LED flashes green once every 1 second	
Fault/Low power	Red LED flashing continuously	
Flush duration button pressed down	Green LED flashes rapidly	
Valve open during flush time programming	Red LED flashes rapidly	
Boot Up	Red/Green LED flashes alternately	

If you need any assistance please do not hesitate to contact the team at Supakwik using the contact details on the back of this manual.

Spare Parts

The spare parts below are available from Supakwik Water Heaters, contact us via the details on the back of this manual to order any parts you require.

The items below have the description followed by the part number in brackets.

9 Volt Solenoid Valve (**RP0081**)

Solenoid Valve Diaphragm Kit (**RP0083**)

9 Volt Battery Pack (**RP0082**)

9 Volt Transformer - Mains Power Supply (**RP0087**)

Sensor to Solenoid Valve Cable (**RP0088**)

Sensor Assembly – Ceiling Mounted, Battery Powered (**SFCB02**)

Sensor Assembly – Ceiling Mounted, Mains Powered (**SFCM02**)

S Sensor Assembly – Wall Mounted, Battery Powered (**SFWB02**)

Sensor Assembly – Wall Mounted, Mains Powered (**SFWM02**)

Accessories

Air Break ½" x 1" Chromed DR Brass (**AC1050**)

Air Break ½" x 1¼" Chromed DR Brass (**AC1060**)

Air Break ½" x 1½" Chromed DR Brass (**AC1070**)

1. Warranty, Terms, and Conditions

- 1.1 Our goods come with guarantees that cannot be excluded under the Australian Consumer Law. You are entitled to a replacement or refund for a major failure and compensation for any other reasonably foreseeable loss or damage. You are also entitled to have the goods repaired or replaced if the goods fail to be of acceptable quality and the failure does not amount to a major failure.
- 1.2 Supakwik Water Heaters Pty. Ltd. guarantees your product against faulty manufacture or mechanical defect for the period as stipulated below:

2 Years warranty – The first 12 months parts and labour, the following 12 months parts only.
- 1.3 Supakwik reserves the right to choose whether to:
 - a. Repair the product,
 - b. Replace the product or part with an equivalent, or
 - c. Refund the cost of the product.
- 1.4 After a product has been repaired or replaced under warranty, the product will still be under warranty for the remaining warranty period.
- 1.5 Filters are not covered under warranty as their lifespan is dictated by the quality and quantity of the water that passes through it.
- 1.6 The unit must be installed in accordance with the local water & electrical supply authority regulations, to be eligible for warranty.
- 1.7 The unit must be operated and maintained in line with “Care and Cleaning” instructions to be eligible for warranty.
- 1.8 The warranty claim must be made within the warranty period to be eligible.
- 1.9 The warranty period commences from the date of purchase.
- 1.10 If Supakwik is engaged to replace or repair a product under warranty, and there is no fault or the fault is found to be ineligible for a warranty claim, the claimant will be liable for all the costs involved, it will then be their choice whether or not to go ahead with repairs.

1.11 This warranty is not transferable and only applies to the original owner.

1.12 This warranty is only valid within Australia.

2. Warranty Exclusions:

2.1 This warranty does not exclude, limit or modify any warranty condition obligation or liability which is or may be implied or imposed on the company by virtue of the Australian Consumer Law, or any other statute, rule, or regulation except for the extent to which the company is lawfully entitled to exclude limit or modify it.

2.2 Supakwik Water Heaters Pty Ltd is not liable:

- a. For the cost of removal, shipping, and or reinstallation of a product or part that needs to be repaired or returned to Supakwik Water Heaters.
- b. For the cost of travelling to and from a location, to repair or replace a product or part.
- c. For attempted repair or damage by unauthorised service people.
- d. If malfunction or damage is caused to a part or product due to lime Scale, dissolved mineral build up, or sediment as a result of poor water quality.
- e. If the water supply is non potable.
- f. If any modifications or third party parts are fitted, this includes filters.
- g. If the product is used for which it was not designed or intended.
- h. Unless the product has been installed as per the installation instructions supplied with the product.
- i. Unless the product has been installed by a person licenced to do so.
- j. If the product or part has been damaged due to:
 - (i) Misuse or abnormal use.
 - (ii) Accidental damage.
 - (iii) Neglect.
 - (iv) Acts of God, such as cyclones, lightning strikes, flooding etc.

- (v) Continued use after the fault has become apparent.
- k. If the serial number or rating label, which identifies the product has been removed or tampered with.
- l. For additional costs involved to access products.
- m. For general wear and tear.
- n. Damage that occurred during transport.
- o. For the life of the battery.

How to make a warranty claim

If you have a product that you feel meets the requirements above and has become faulty please contact Supakwik via email at services@supakwik.com or phone (07) 3800 0575. Supakwik must be contacted before any works have commenced on a product, or is returned to us for repair or replacement under warranty. Failure to comply may result in the warranty void.

Supakwik Water Heaters
3/7 St Jude Ct,
Browns Plains, 4118,
Queensland.

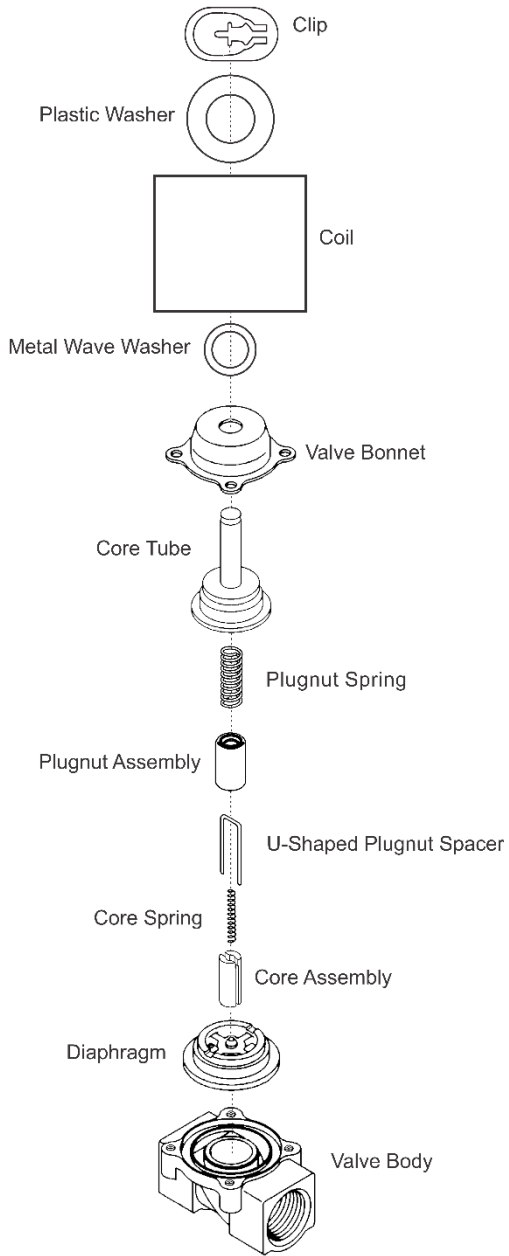



3/7 St Jude Ct, Browns Plains, QLD 4118

T (07) 3800 0575

sales@supakwik.com.au

supakwik.com.au